

Body-Solid®

Built for Life

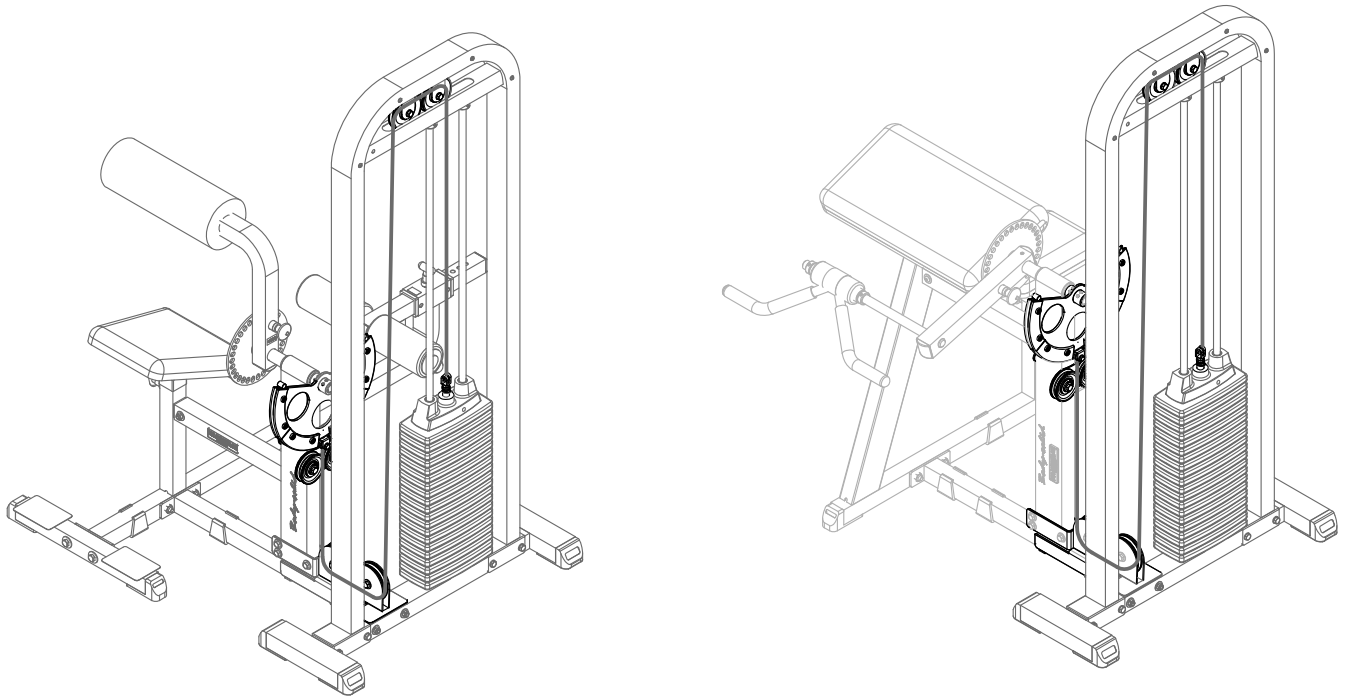

GCABBT-KITB

Assembly & Instructions
OWNER'S & MANUAL

V. 20240103

Warning, Safety & Maintenance

Be sure that all users carefully read and understand all warning, safety and maintenance labels on the machine before each use. Failure to do so may result in death or serious injury.

It is imperative that you retain this Owner's Manual and be sure all warning labels are legible and intact. Replacement Owner's Manuals and warning labels are available from your local Body-Solid dealer.

If you have any questions about the operation, set up or maintenance of this machine please call our customer service department at 1 (800) 556-3113.

MAINTENANCE SCHEDULE	
Check the function and integrity of the following components. As noted, inspect equipment before each workout. Replace all damaged, broken or worn components immediately.	
Cables: Check tension, end fittings, and coating	✓
Check that locking nut at weight stack is tight	✓
Upholstery: Wipe down and dry	✓
Clean and condition	✓
Frame: Wipe down and dry	✓
Polish / Wax	✓
Chrome: Wipe down and dry	✓
Polish / Lubricate	✓
Nut / Bolts / Fasteners: Tighten and / or adjust as needed	✓
Guide Rods: Lubricate and clean	✓
Linear Rods: Lubricate and clean	✓
Seat Sleeves: Lubricate and clean	✓
Adjustments / Locking Pins / Tightening Knobs	✓
Weight Stack Pins	✓
Warning Instruction Labels	✓
Springs / Pop Pins	✓
Anti Skid Surfaces	✓
Hand Grips / Rollers	✓

For Body-Solid Customer Service
Call **1-800-556-3113**
#MSSTR0008

CAUTION

THERE IS A RISK ASSUMED BY INDIVIDUALS WHO USE THIS TYPE OF EQUIPMENT. TO MINIMIZE RISK, YOU MUST FOLLOW THESE RULES:

Inspect equipment before each workout.
Check that all nuts and bolts are in place and fully tightened.
Also, before use, check for signs of wear. Replace all worn parts immediately.
Never use equipment if any parts are damaged or missing.

FAILURE TO FOLLOW THESE RULES MAY RESULT IN INJURY.

Exercise with care. Perform your exercise at a smooth, moderate pace; never perform jerky or uncoordinated movements that may cause injury.
DO NOT allow children or minors to play on or around this equipment.
If unsure of proper use of equipment, call your local Body-Solid distributor or the Body-Solid customer service center at (800) 556-3113.
Consult your physician before starting your exercise program.
For your own safety, DO NOT begin any exercise program without proper instruction.

WARNING!

Safety and Maintenance of Cables

IMPORTANT: Cables are wear items. It is your responsibility to prevent unexpected breakage.
Cable inspection should be performed daily.

Inspect all cables, the nylon coating on all cables, and the area near fitting at each end of each cable.
Replace and damaged or worn cable immediately.

Do not allow the machine to be used until damaged or worn cables are replaced. Using or allowing a machine to be used with a suspect cable can result in serious injury. See Owner's Manual for more information.

For Body-Solid Customer Service
Call **1-800-556-3113**

Table of Contents

- SAFTEY INSTRUCTIONS.....PAGE 2
- PREPARATION.....PAGE 5
- ASSEMBLY INSTRUCTIONS For GCAB360...PAGE 6
- ASSEMBLY INSTRUCTIONS For GCBT380...PAGE 14
- HARDWARE LIST.....PAGE 22
- MAINFRAME PART LIST.....PAGE 23
- HARDWARE ILLUSTRATION.....PAGE 24
- EXPLODED VIEWS.....PAGE 26
- CONTACT PAGE.....PAGE 28

Important Safety Instructions

Before beginning any fitness program, you should obtain a complete physical examination from your physician.

*Il est conseillé de subir un examen médical complet avant d'entreprendre tout programme d'exercice.
Si vous avez des étourdissements ou des faiblesses, arrêtez les exercices immédiatement.*

Antes de comenzar cualquier programa de ejercicios, deberías tener un examen físico con su doctor.

When using exercise equipment, you should always take basic precautions, including the following:

- Read all instructions before using the **GCABBT-KIT**. These instructions are written to ensure your safety and to protect the unit.
- **Do not remove any safety labels from the machine.**
- Do not allow children on or near the equipment.
- Use the equipment only for its intended purpose as described in this guide. Do not use accessory attachments that are not recommended by the manufacturer. Such attachments might cause injuries.
- Wear proper exercise clothing and shoes for your workout, no loose clothing.
- Keep hands, limbs, loose clothing, and long hair well out of the way of all moving parts.
- Use care when getting on or off the unit.
- Do not overexert yourself or work to exhaustion.
- If you feel any pain or abnormal symptoms, stop your workout immediately and consult your physician.
- Never operate unit when it has been dropped or damaged. Return the equipment to a service center for examination and repair.
- Never drop or insert objects into any opening in the equipment.
- Always check the unit and its cables before each use. Make sure that all fasteners and cables are secure and in good working condition.
- Do not use the equipment outdoors or near water.

Personal Safety During Assembly

- Before beginning assembly, please take the time to read the instructions thoroughly.
- Read each step in the assembly instructions and follow the steps in sequence. Do not skip ahead. If you skip ahead, you may learn later that you have to disassemble components and that you may have damaged the equipment.
- Assemble and operate the **GCABBT-KIT** on a solid level surface. Locate the unit a few feet from the walls or furniture to provide easy access.

The **GCABBT-KIT** is designed for your enjoyment. By following these precautions and using common sense, you will have many safe and pleasurable hours of healthful exercise with your Body-Solid **GCABBT-KIT**.

After assembly, you should check all functions to ensure correct operation. If you experience problems, first recheck the assembly instructions to locate any possible errors made during assembly. If you are unable to correct the problem, call the dealer from whom you purchased the machine or call **1-800-556-3113** for the dealer nearest you.

Obtaining Service

Please use this Owner's Manual to make sure that all parts have been included in your shipment. When ordering parts, you must use the part number and description from this Owner's Manual. Use only Body-Solid replacement parts when servicing this machine. Failure to do so will void your warranty and could result in personal injury.

For information about product operation or service, check out the official Body-Solid website at www.bodysolid.com or contact an authorized Body-Solid dealer or a Body-Solid factory-authorized service company or contact Body-Solid customer service at one of the following:

Toll Free: 1-800-556-3113
Phone: 1-708-427-3555
Fax: 1-708-427-3556
Hours: M-F 8:30-5:00 CST
E-Mail: service@bodysolid.com

**Or write to: Body-Solid, Inc.
Service Department
1900 S. Des Plaines Ave.
Forest Park, IL 60130 USA**

Retain this Owner's Manual for future reference. If you need to order replacement parts please be prepared to provide the following information when contacting us so that we can assist you better.

- 1. Model Number**
- 2. Place of Purchase**
- 3. Serial Number (S/N)**
- 4. Part # and Description**

Preparation

Thank you for purchasing the **GCABBT-KIT**. This bench is part of the Body-Solid line of quality strength training machines, which lets you target specific muscle groups to achieve better muscle tone and overall body conditioning. To maximize your use of the equipment please study this Owner's Manual thoroughly.

Required Tools

The basic tools that you must obtain before assembling the **GCABBT-KIT** include but are not limited to:

- Metric Allen Key Set
- Standard Allen Key Set
- Standard Wrench Set
- Metric Wrench Set
- Adjustable Wrench
- Screwdriver (standard and/or phillips)

Installation Requirements

Follow these installation requirements when assembling the **GCABBT-KIT**:

Set up the **GCABBT-KIT** on a solid, flat surface. A smooth, flat surface under the machine helps keep it level. A level machine has fewer malfunctions.

Provide ample space around the machine. Open space around the machine allows for easier access.

Insert all bolts in the same direction. For aesthetic purposes, insert all bolts in the same direction unless specified (in text or illustrations) to do otherwise.

Leave room for adjustments. Tighten fasteners such as bolts, nuts, and screws so the unit is stable, but leave room for adjustments. Do not fully tighten fasteners until instructed in the assembly steps to do so.

Fill out and mail the warranty card.

Assembly Tips

Read all "Notes" on each page before beginning each step.

While you may be able to assemble the **GCABB-KIT** using the illustrations only, important safety notes and other tips are included in the text.

Some pieces may have extra holes that you will not use. Use only those holes indicated in the instructions and illustrations.

NOTE: With so many assembled parts, proper alignment and adjustment is critical. While tightening the nuts and bolts, be sure to leave room for adjustments.

NOTE: The bottles that are marked "Poison" is your touch up paint. Keep away from children.

CAUTION: Obtain assistance! If you feel like you can't assemble the **GCABBT-KIT** by yourself then do not attempt to do so as this could result in injury. Review the installation requirement before proceeding with the following steps.

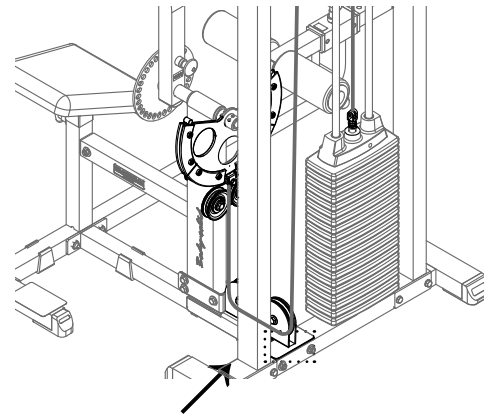

Your S/N# can
be found here

Body-Solid continually seeks ways to improve the performance, specifications and product manuals in order to ensure that only superior products are released from our factories. Please take the time to carefully read through this manual thoroughly. Instructions contained in this document are not intended to cover all details or variations possible with Body-Solid equipment, or to cover every contingency that may be met in conjunction with installation, operation, maintenance or troubleshooting of the equipment. Even though we have prepared this manual with extreme care, neither the publisher nor the author can accept responsibility for any errors in, or omission from, the information given. Should additional information be required, or should situations arise that are not covered by this manual, the matter should be directed to your local Body-Solid representative, or the Service Department at Body-Solid Inc. in Forest Park, Illinois.

STEP**1**

Be careful to assemble all components in the sequence they are presented.

NOTE:

Finger tighten all hardware in this step. **DO NOT** wrench tighten until the last step. Some components may be pre-assembled. Nylon lock nuts will not fully screw onto bolts, they must be wrench tighten to fully go on.

- 1A.** Disassemble Ab/Back Weight Plate Arm (D)_{GCAB-360} by loosening four M8x8 AllenScrews (#30)_{GCAB-360} & removing Pin (#28)_{GCAB-360}

Caution: Rotating Arm (E)_{GCAB-360} may fall down when you disassemble the Weight Plate Arm (D)_{GCAB-360}

- 1B.** Slide Cam (A) into the Ab/Back Adjuster (G)_{GCAB-360}
- 1C.** Insert Pin (#28_{GCAB-360} or #21_{GCABB-T-KIT}) into the Ab/Back Adjuster (G)_{GCAB-360}, then secure Ab/Back Adjuster (G)_{GCAB-360} by tightening four Allen Screws (#8) on Cam (A).
- 1D.** Attach Cable with Hole End (#20) to Cam (A) using:
Two spacer sleeve (#17)
One sleeve (#18)
One M8x40 hex head bolt (#5)
Two M8 washers (#10)
One M8 nylon lock nut (#12)

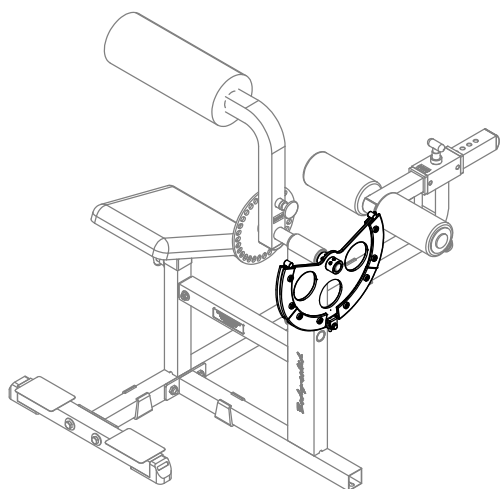

Above shows Step 1 assembled and completed.

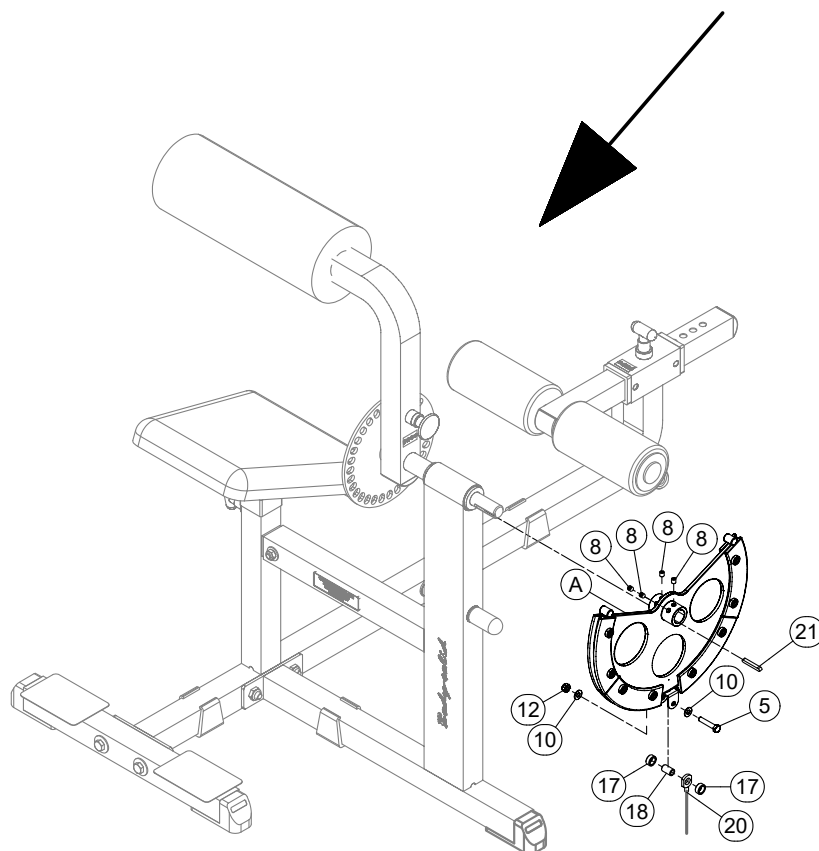
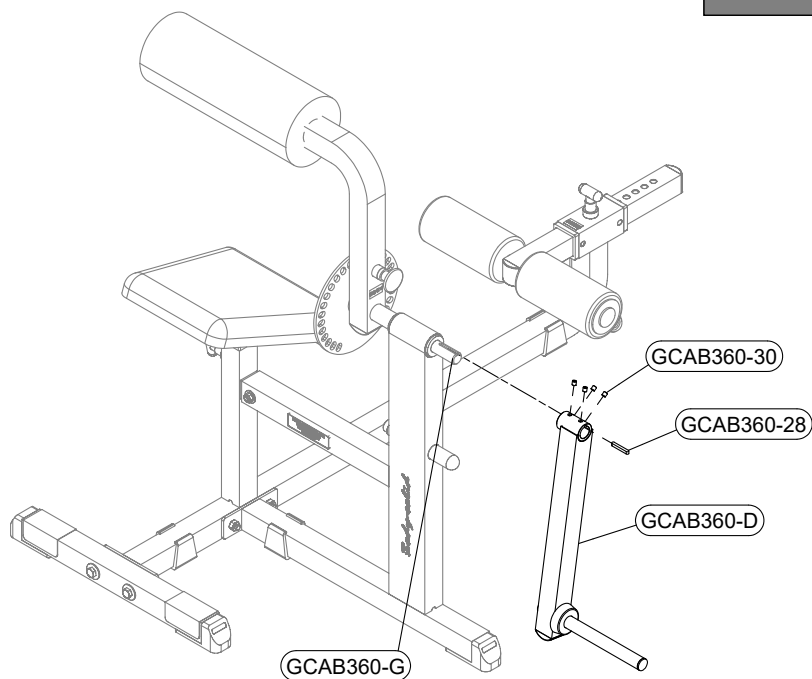

STEP**2**

Be careful to assemble all components in the sequence they are presented.

NOTE:

Finger tighten all hardware in this step. DO NOT wrench tighten until the last step. Some components may be pre-assembled. Nylon lock nuts will not fully screw onto bolts, they must be wrench tighten to fully go on.

- 2A.** Remove Shaft (K)_{GCAB-360}.
- 2B.** Install Pulley Holder (C) into Ab/Back Frame (B)_{GCAB-360} using:
 - one M10x25 allen head bolt (#7)**
 - one M10 washer (#19)**
- 2C.** Install two Pulleys (#14) into the Pulley Holder (C) using:
 - Two M10x40 hex head bolts (#4)**
 - Four M10 washer (#9)**
 - Two M10 nylon lock nuts (#11)**
- 2D.** Route Cable (#20) between the two Pulleys (#14). **Please note that you may need to un-install one of the Pulleys in order to route the cable.**

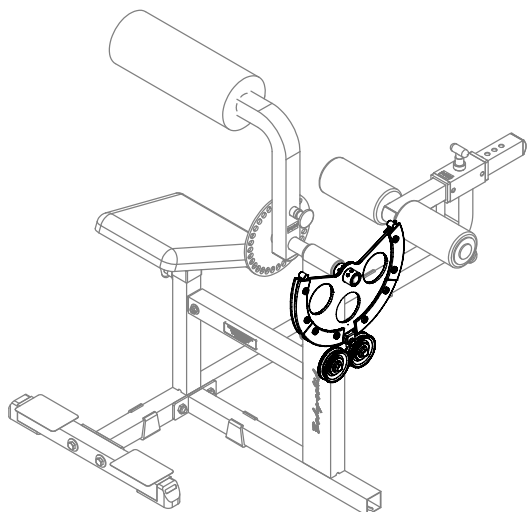

Above shows Step 2 assembled and completed.

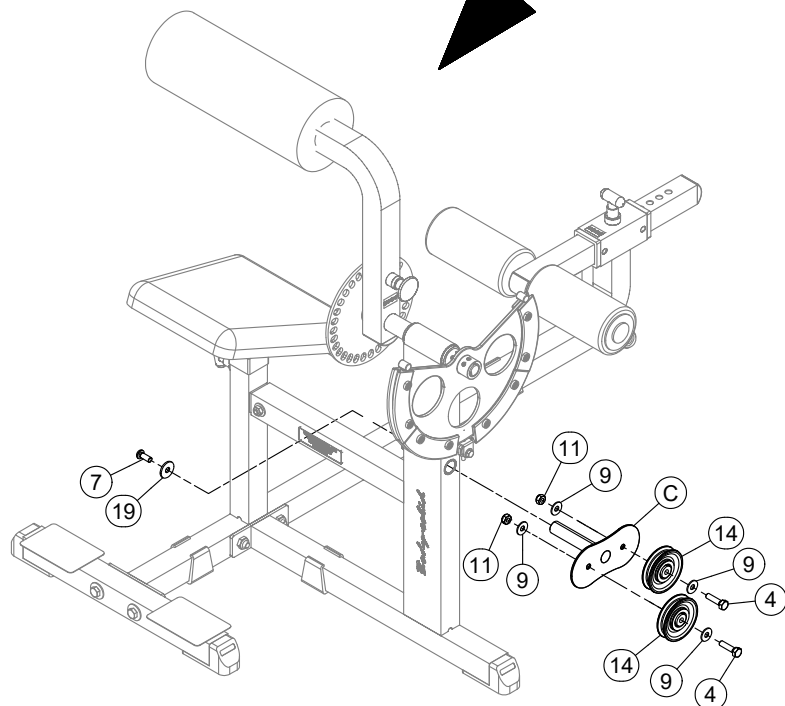
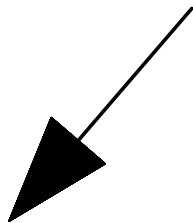
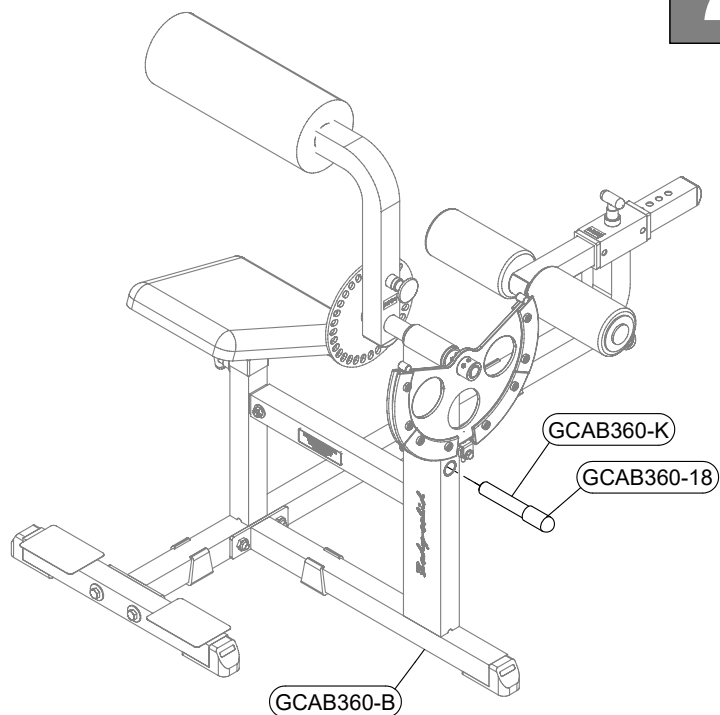

STEP**3**

Be careful to assemble all components in the sequence they are presented.

NOTE:

Finger tighten all hardware first in this step. Wrench tighten ALL hardware at the end of STEP 3D. Some components may be pre-assembled. Nylon lock nuts will not fully screw onto bolts, they must be wrench tighten to fully go on.

- 3A.** Disassemble Foot Cap (#10)_{GCAB-360} from Ab/Back Frame (B)_{GCAB-360}
- 3B.** Attach Double Pulley Holder (B) to Lower Base Frame (A)_{GSTACK} using:
Two M10x95 hex head bolts (#1)
Four M10 washer (#9)
Two M10 nylon lock nuts (#11)
- 3C.** Attach Double Pulley Holder (B) to Ab/Back Frame (B)_{GCAB-360} using:
Three M10x75 hex head bolt (#2)
Six M10 washer (#9)
Three M10 nylon lock nuts (#11)
- 3D.** Route cable through the Double Pulley Holder (B) before installing the two pulleys (#15).
- 3E.** Install Two Pulleys (#15) into the Double Pulley Holder (B) using:
Two M10x45 hex head bolts (#3)
Four M10 washer (#9)
Two M10 nylon lock nuts (#11)

STEP
3

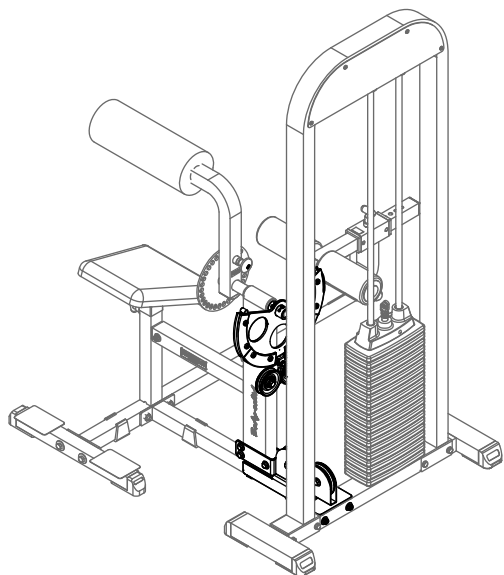

Above shows Step 3 assembled and completed.

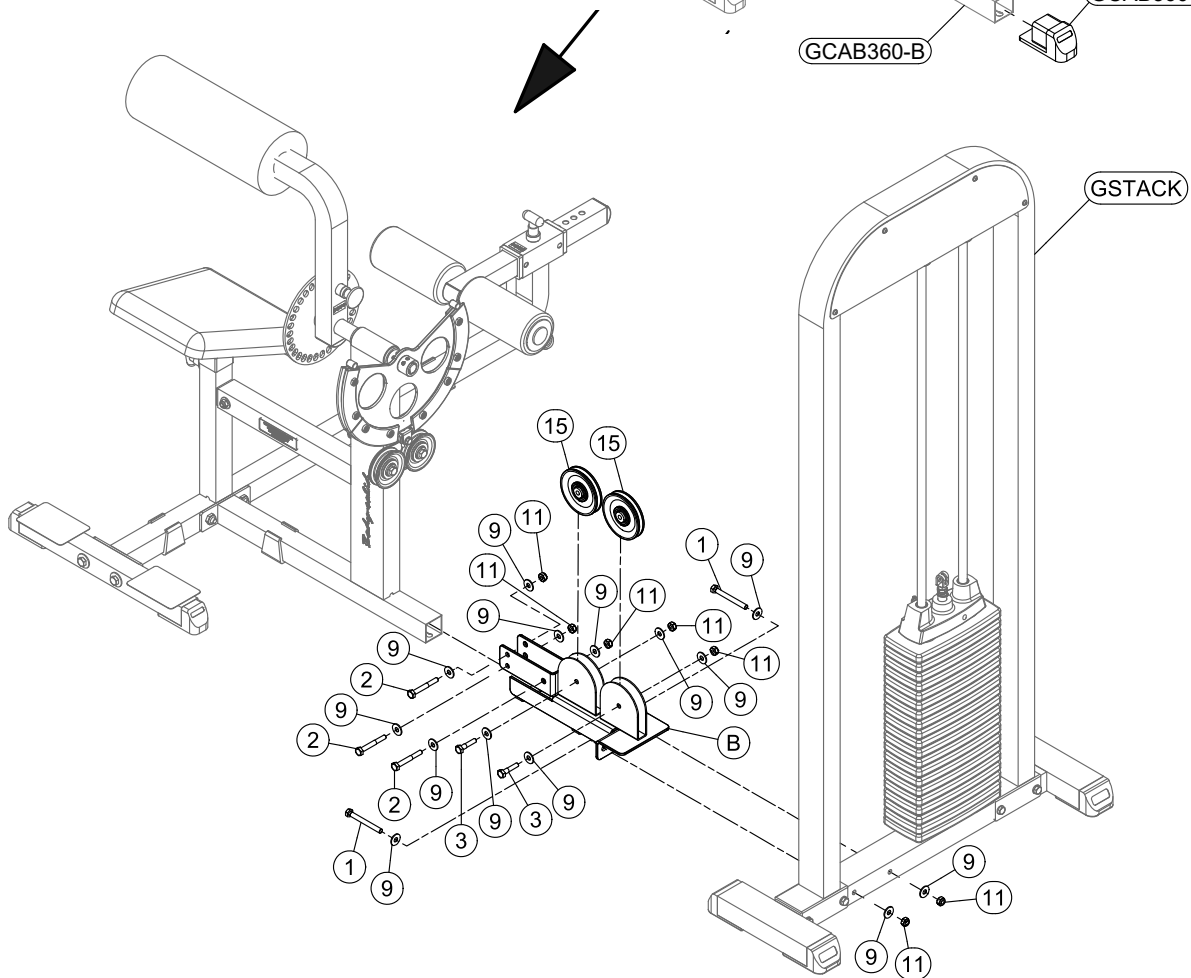
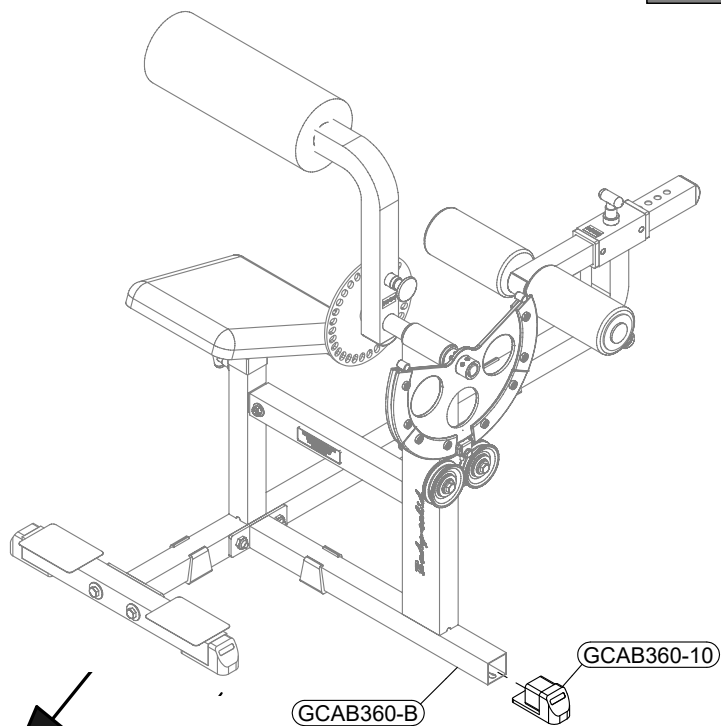

STEP**4**

Be careful to assemble all components in the sequence they are presented.

- 4A.** Route Cable (#20) as shown in Step 4 Drawing and attached Cable with chain end (#20) to the GSTACK

IMPORTANT NOTE:

Disassemble and do not use the Cable and Floating Pulley Bracket from G-STACK. Attach Cable (#20) to Selector Rod Top Bolt per Step 3 drawing instruction from G-STACK manual.

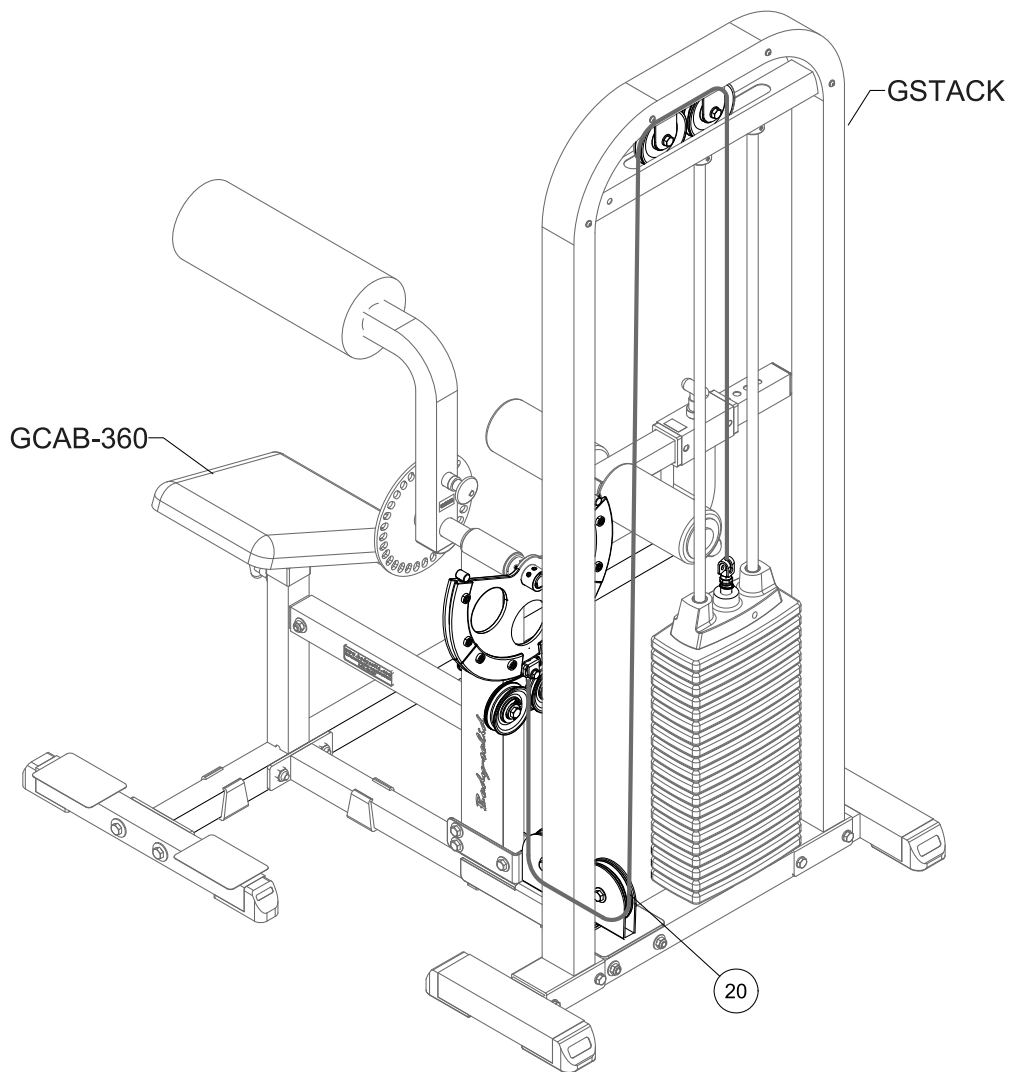

STEP**1**

Be careful to assemble all components in the sequence they are presented.

NOTE:

Finger tighten all hardware in this step. **DO NOT** wrench tighten until the last step. Some components may be pre-assembled. Nylon lock nuts will not fully screw onto bolts, they must be wrench tighten to fully go on.

- 1A.** Disassemble Preacher Curl Weight Plate Arm (E)_{GCBT-380} by loosening four M8x8 Allen Screws_{GCBT-380} & removing Pin (PIN)_{GCBT-380}.

Caution: Preacher Curl Arm (H)_{GCBT-380} may fall down when you disassemble the Preacher Curl Arm (E)_{GCBT-380}.

- 1B.** Slide Cam (A) into the Preacher Curl Adjuster (G)_{GCBT-380}.
- 1C.** Insert Pin (#21) into the Preacher Curl Adjuster (G)_{GCBT-380}, then secure Preacher Curl Adjuster (G)_{GCBT-380} by tightening four Allen Screws (#8) on Cam (A).
- 1D.** Attach Cable with Hole End (#20) to Cam (A) using:
- Two spacer sleeve (#17)**
 - One sleeve (#18)**
 - One M8x40 hex head bolt (#5)**
 - Two M8 washers (#10)**
 - One M8 nylon lock nut (#12)**

STEP**2**

Be careful to assemble all components in the sequence they are presented.

NOTE:

Finger tighten all hardware in this step. DO NOT wrench tighten until the last step. Some components may be pre-assembled. Nylon lock nuts will not fully screw onto bolts, they must be wrench tighten to fully go on.

- 2A.** Remove Shaft (K)_{GCBT-380}
- 2B.** Install Pulley Holder (C) into Preacher Curl Frame (B)_{GCBT-380} using:
one M10x25 allen head bolt (#7)
one M10 washer (#19)
- 2C.** Install two Pulleys (#14) into the Pulley Holder (C) using:
Two M10x40 hex head bolts (#4)
Four M10 washer (#9)
Two M10 nylon lock nuts (#11)
- 2D.** Route Cable (#20) between the two Pulleys (#14). **Please note that you may need to un-install one of the Pulleys in order to route the cable.**

STEP
2

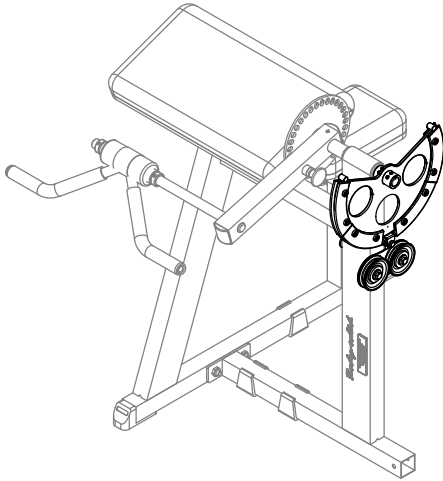

Above shows Step 2 assembled and completed.

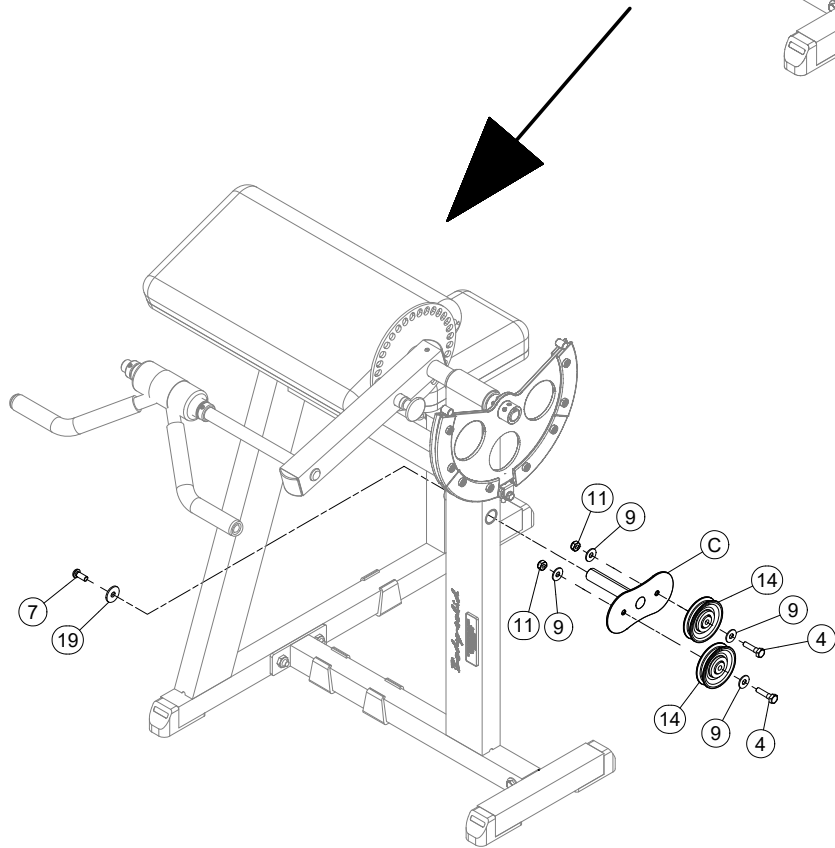
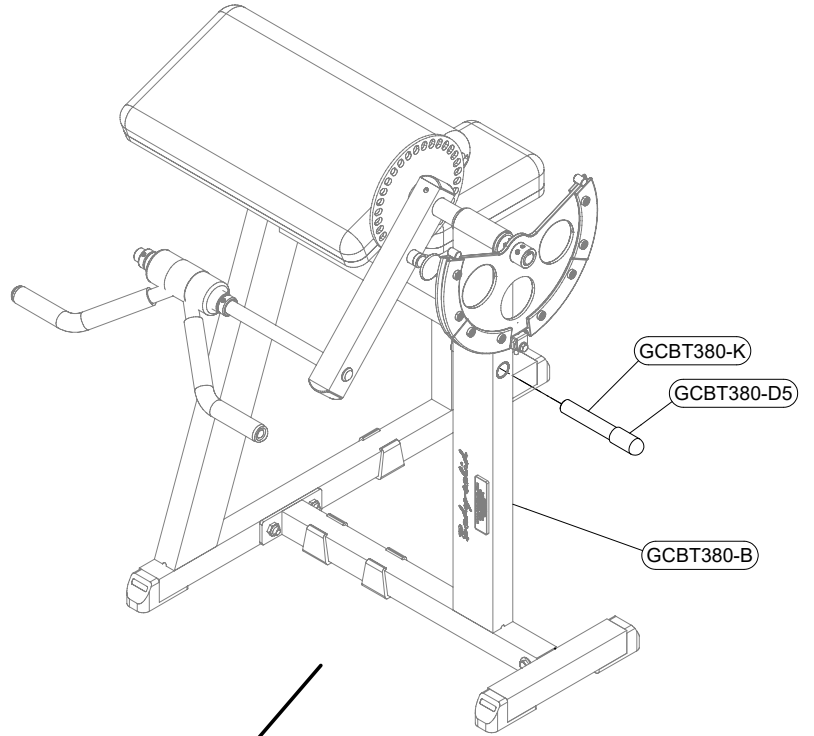

STEP**3**

Be careful to assemble all components in the sequence they are presented.

NOTE:

Finger tighten all hardware first in this step. Wrench tighten ALL hardware at the end of STEP 3D. Some components may be pre-assembled. Nylon lock nuts will not fully screw onto bolts, they must be wrench tighten to fully go on.

- 3A.** Disassemble Lower Frame (C) _{GCBT-380} from Preacher Curl Frame (B) _{GCBT-380} by removing
One M12x75 hex head bolt (A2) _{GCBT-380}
Two M10 washers (C2) _{GCBT-380}
One M10 nylon lock nut (B2) _{GCBT-380}
- 3B.** Attach Double Pulley Holder (B) to Lower Base Frame (A) _{GSTACK} using:
Two M10x95 hex head bolts (#1)
Four M10 washer (#9)
Two M10 nylon lock nuts (#11)
- 3C.** Attach Double Pulley Holder (B) to Preacher Curl Frame (B) _{GCBT-380} using:
Three M10x75 hex head bolt (#2)
Six M10 washer (#9)
Three M10 nylon lock nuts (#11)
- 3D.** Route cable through the Double Pulley Holder (B) before installing the two pulleys (#15).
- 3E.** Install Two Pulleys (#15) into the Double Pulley Holder (B) using:
Two M10x45 hex head bolts (#3)
Four M10 washer (#9)
Two M10 nylon lock nuts (#11)

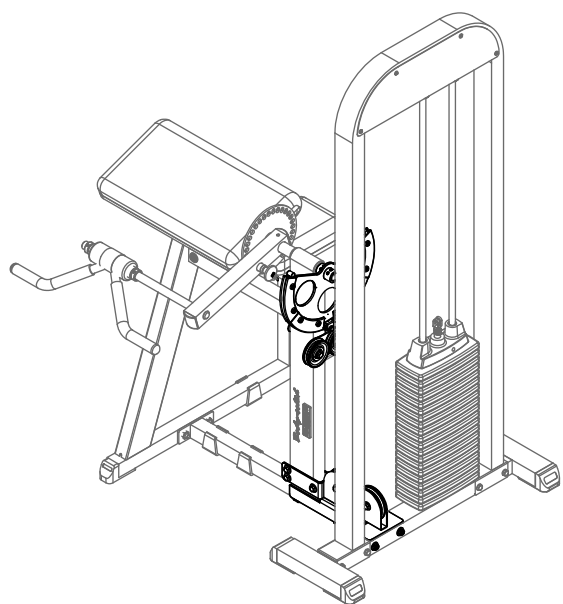

Above shows Step 3 assembled and completed.

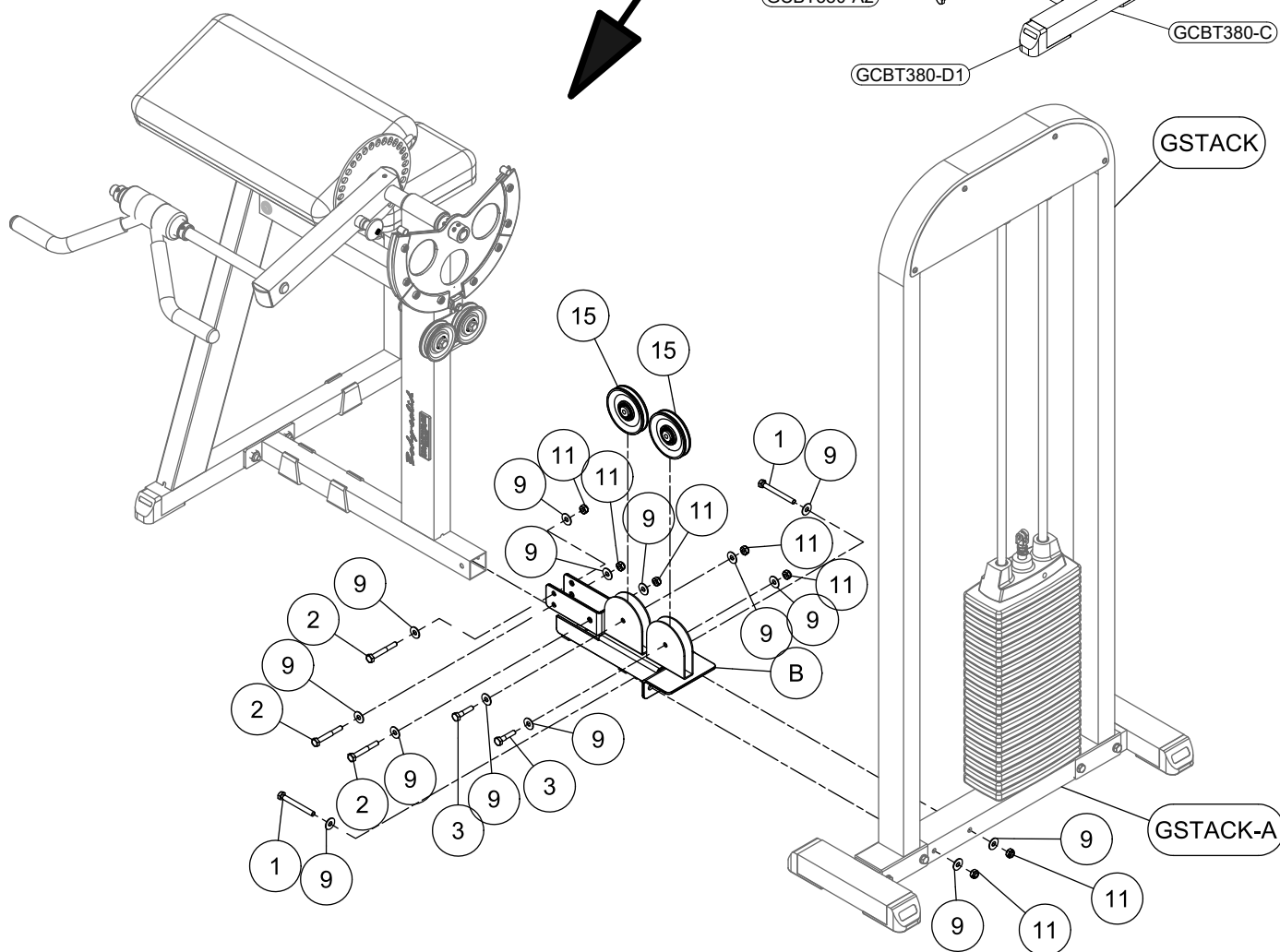
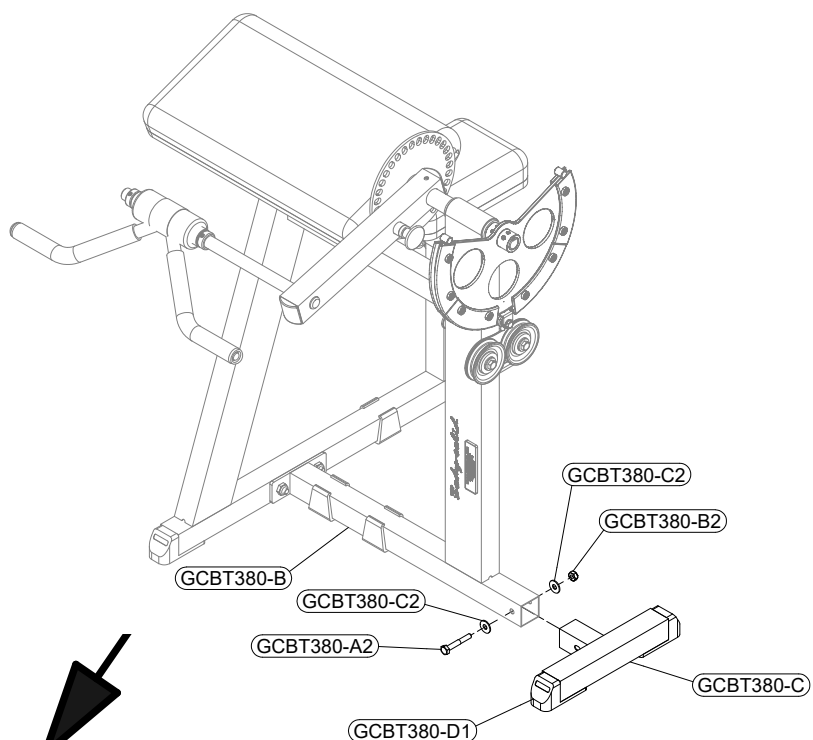

STEP**4**

Be careful to assemble all components in the sequence they are presented.

- 4A.** Route Cable (#24) as shown in Step 4 Drawing and attached Cable with chain end (#24) to the GSTACK

IMPORTANT NOTE:

Disassemble and do not use the Cable and Floating Pulley Bracket from G-STACK. Attach Cable (#24) to Selector Rod Top Bolt per Step 3 drawing instruction from G-STACK manual.

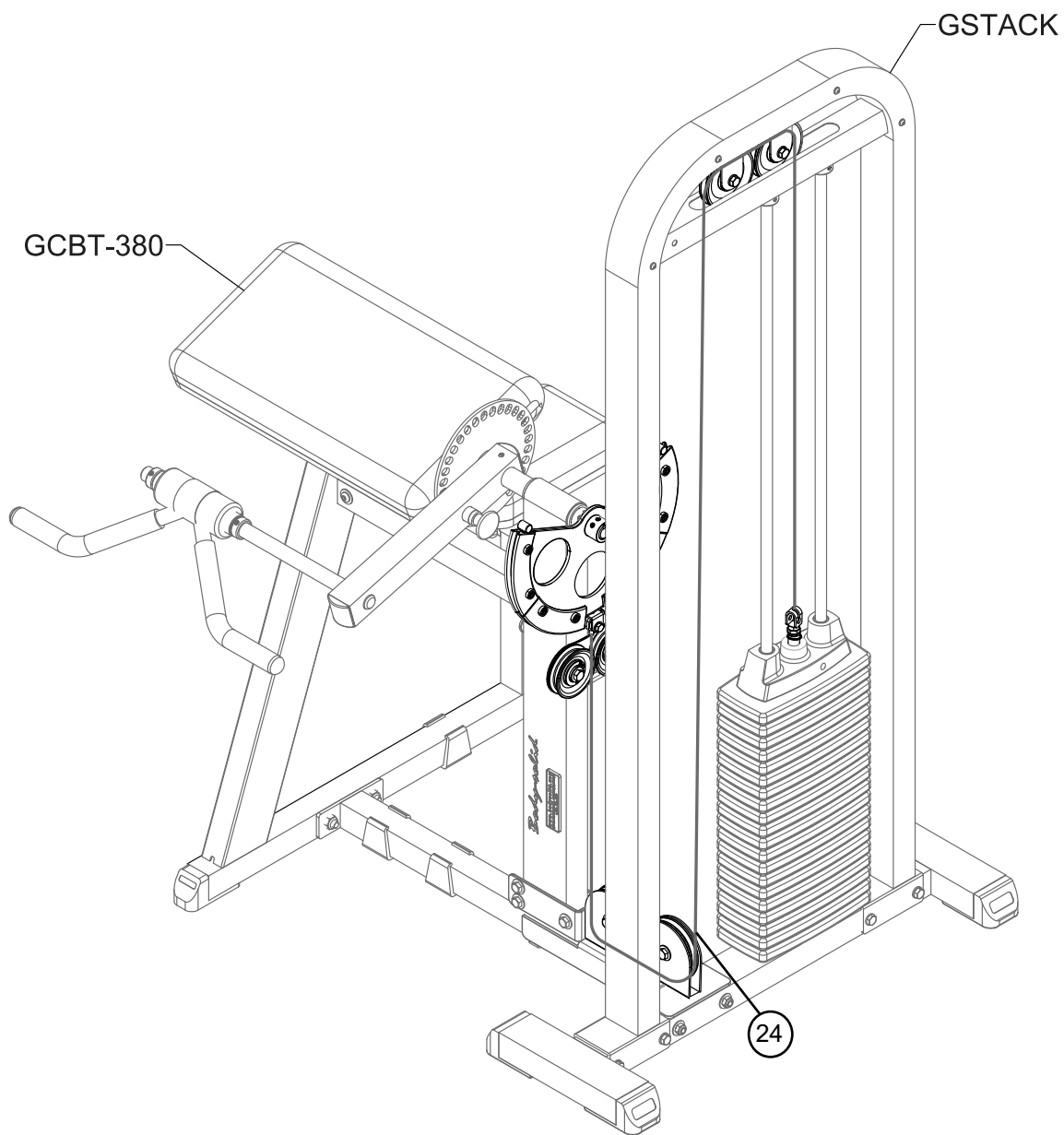

GCABB T - K I T H a r d w a r e L i s t

Part#	Size	Description	Quantity
1	M10X95mm	HEX HEAD BOLT	2
2	M10X75mm	HEX HEAD BOLT	3
3	M10X45mm	HEX HEAD BOLT	2
4	M10X40mm	HEX HEAD BOLT	2
5	M8x40mm	HEX HEAD BOLT	1
6	M6x25mm	SOCKET HEAD BOLT (Pre-Installed)	8
7	M10x25mm	ALLEN HEAD BOLT (Pre-Installed)	1
8	M8x8mm	ALLEN SCREW (Pre-Installed)	4
9	M10	WASHER	18
10	M8	WASHER	2
11	M10	NYLON LOCK NUT	9
12	M8	NYLON LOCK NUT	1
13	M6	NYLON LOCK NUT (Pre-Installed)	8
14	3-1/2"	PULLEY	2
15	4-1/2"	PULLEY	2
16	NA	CAM CABLE TRACK (Pre-Installed)	4
17	NA	SPACER SLEEVE	2
18	NA	SLEEVE	1
19	NA	WASHER (Pre-Installed)	1
20	134"	GCAB 360 CABLE	1
21	NA	PIN	1
22	NA	SNAP LINK	1
23	NA	STEEL CHAIN 6"	1
24	141.25"	GCBT380 CABLE	1

GCABB T-KIT Mainframe Parts List

Part#	Description	Quantity
A	CAM	1
B	DOUBLE PULLEY HOLDER	1
C	PULLEY HOLDER	1

GCABBT-KIT Hardware Illustration

PART#1 HEX HEAD BOLT M10X95 QTY.2

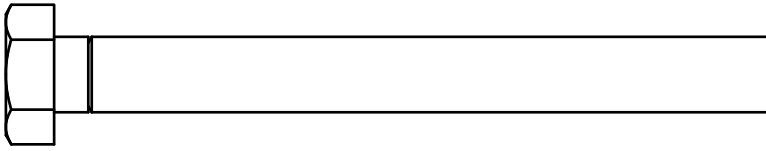

PART#2 HEX HEAD BOLT M10X75 QTY.3

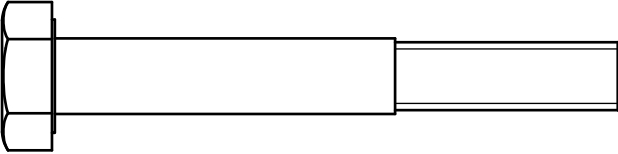

PART#3 HEX HEAD BOLT M10X45 QTY.2

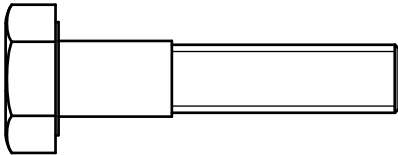

PART#4 HEX HEAD BOLT M10X40 QTY.2

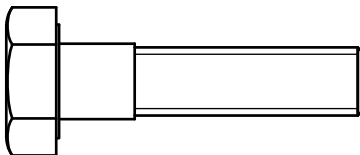

PART#5 HEX HEAD BOLT M8X40 QTY.1

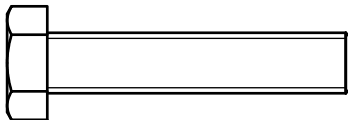

PART#6 SOCKET HEAD BOLT M6X25 (Pre-installed) QTY.8

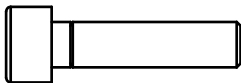

PART#7 ALLEN HEAD BOLT M10X25 (Pre-installed) QTY.1

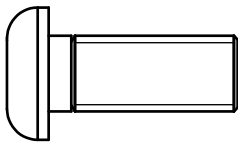

PART#8 ALLEN SCREW M8X8 (Pre-installed) QTY.4

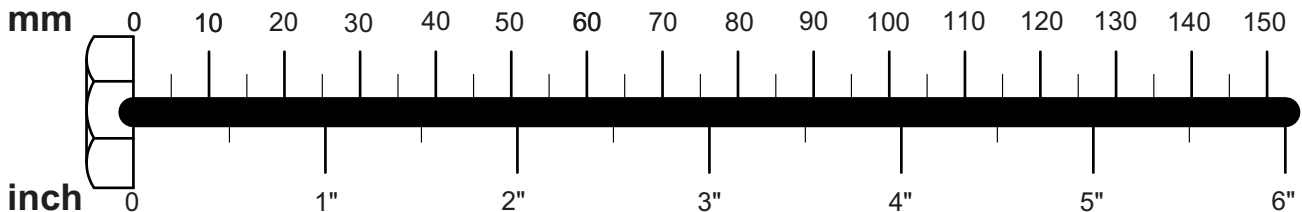

GCABBT-KIT Hardware Illustration

PART#9 M10 WASHER QTY.18

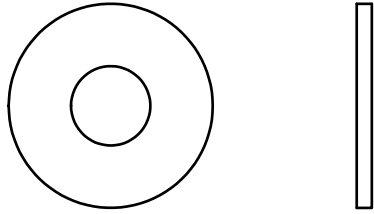

PART#10 M8 WASHER QTY.2

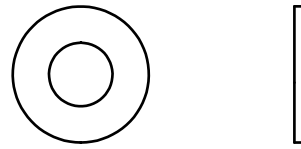

PART#11 M10 NYLON NUT QYT.9

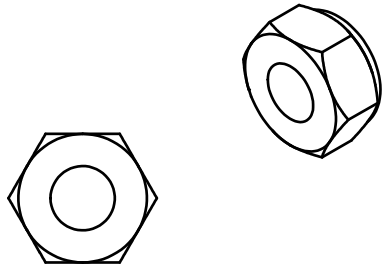

PART#12 M8 NYLON NUT QYT.1

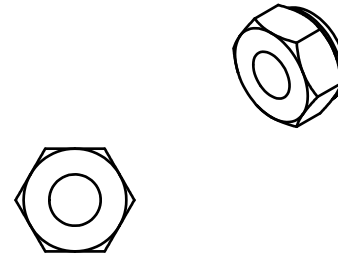

PART#13 M6 NYLON NUT QYT.8

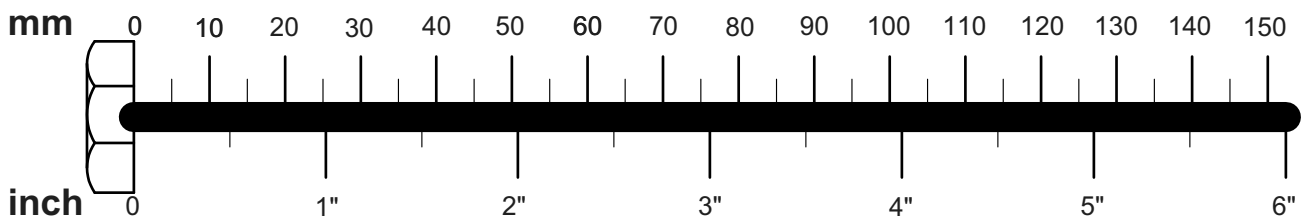
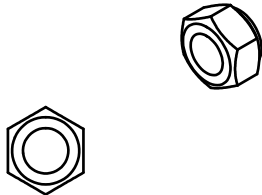

GCABBT-KIT

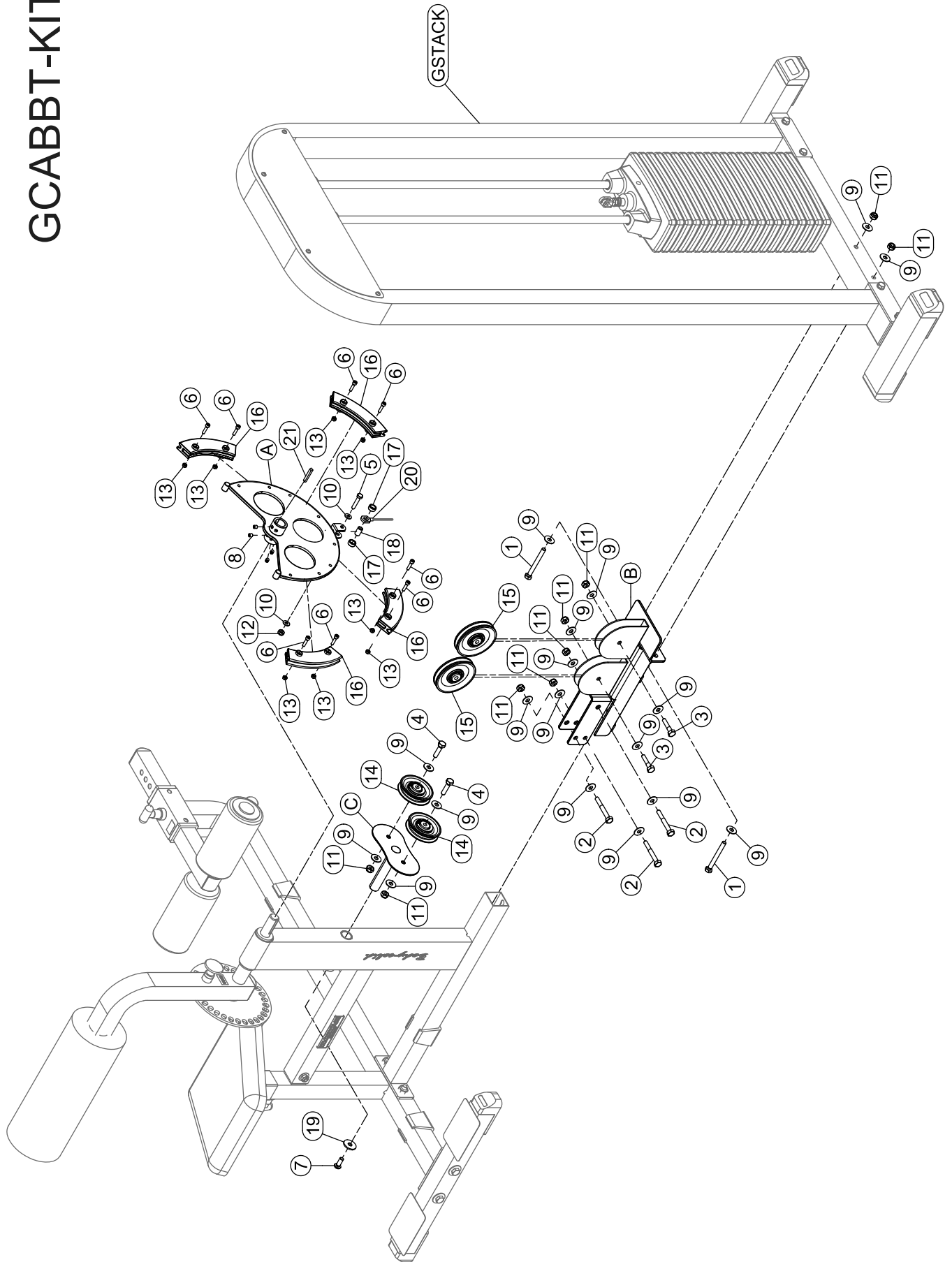

GCABBTKIT Exploded View for GCBT-380

GCABBTKIT

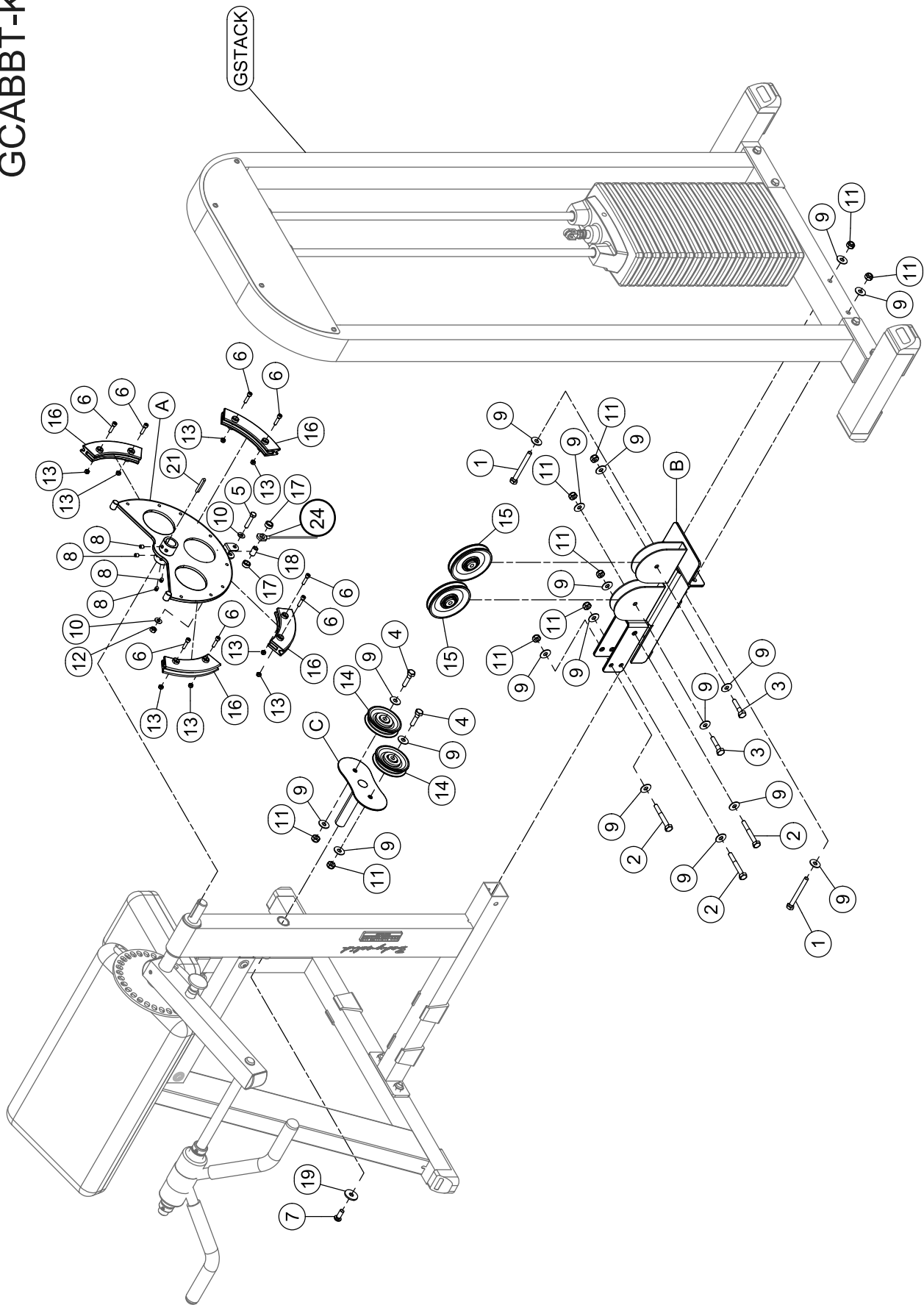



GCABBT-KIT

PLEASE WRITE YOUR SERIAL NUMBER IN THE BOXES BELOW

S/N # 008083----

1900 S. Des Plaines Ave.
Forest Park, IL 60130
Phone:(708)427-3555
Fax:(708)427-3556
Hours: M-F 8:30 - 5:00 CST

www.bodysolid.com